

NOTE:
CORNICE IS INTENDED TO BE INSTALLED USING ONLY THE APPROPRIATE COUNTERSINKING TOOL AND SCREW SYSTEM AS PROVIDED IN THE MELTON SAMPLE PACK. ALL BLOCKING, FASTENERS AND SEALANTS TO BE PROVIDED BY INSTALLER.

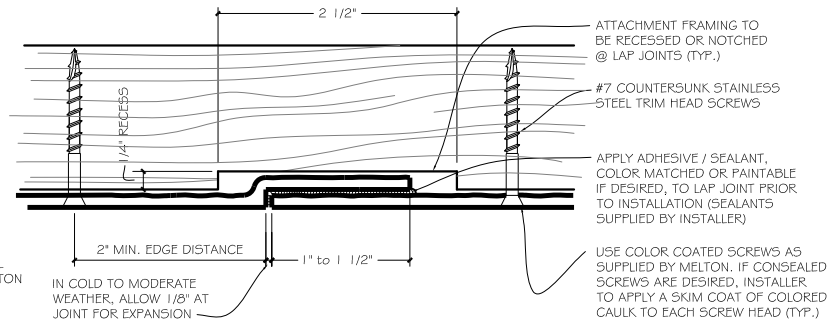

| | |
|---------------|--|
| MC-12 | Melton Classics Incorporated |
| SUBJECT | MC-12 CORNICE DETAILS |
| PROJECT | STANDARD CORNICES |
| CONTRACTOR | MELTON CLASSICS INCORPORATED |
| DRAWN BY: JCH | DATE: 7/13/09 |